

Fire Chief ^{\$995}

Outdoor Woodburning Furnace
Model FCOS2200
Owner's Manual



Volume I
rev. October 2008

Manufactured by: **Victorian Sales**
1808 Larkin Williams Road
Fenton, MO 63026



UL391 Tested by PFS

Congratulations!

You have selected the finest quality outdoor wood burning furnace, manufactured with pride in the USA.

Please take a few moments to carefully read the owner's manual. By taking the time to familiarize yourself with your new Fire Chief Outdoor Furnace, you will be able to look forward to years of trouble-free, dependable service.

Installation

First: Check Local Codes. The installation must comply with all local rulings and requirements.

- *This furnace is an outdoor hot air furnace and must not be installed in a building of any kind.*
- *This unit must be connected to a grounded electrical circuit.*
- *This furnace requires a back-up electric generator, 2000 watts minimum.*
- *Always have a properly installed and functioning smoke detector installed in your home.*
- *To prevent accidental injury, do not allow anyone who is unfamiliar with the furnace to operate it.*
- *Spend time familiarizing yourself with your Fire Chief Furnace, especially the different settings and the effect they have on burn patterns. It is impossible to state how each setting will affect your furnace due to variations in settings, fuels and temperatures.*

Transportation Damages

Every effort has been made to insure that your Fire Chief will arrive in perfect condition. Any visible damage should be noted on the freight bill at the time of delivery. If upon unpacking your Fire Chief you find damage had occurred during transit, notify your supplier immediately. Your supplier will advise you as to what actions must be taken to correct the problem.

Disclaimer Notice

The listed BTU rating of your new Fire Chief was obtained under ideal laboratory testing conditions. The actual BTU output you experience may vary somewhat depending on the type, condition and moisture of the fuel used; the damper adjustment; chimney type and other variable factors. Therefore, the manufacturer disclaims any guarantee as to the BTU output or capacity of your unit.

Manufacturer's Notice

Please be advised that we periodically make changes to improve our products. Therefore the information in this manual may not be completely compatible with your Fire Chief.

**THIS IS AN OUTDOOR WOOD BURNING FURNACE
AND SHOULD NOT BE ALTERED IN ANY WAY!**

TABLE OF CONTENTS

General Specifications, Furnace and Components	4
Installation and Operation	5
Clearances / Test Firing	5
Hot Air Duct and Cold Air Return	6
First Firing, Basic Operation	6
Chimney Requirements	6
Types of installation	8
Installation: Central Duct	8
Installation: Downdraft Furnace or With No Duct Work	9
Fuel Recommendations	10
Ash Removal and Wood Storage	10
Maintenance	11
Parts Diagram	12
Wiring Diagram	13
Troubleshooting Guide	14
Warranty Information	18
Model and Serial Number Registration	19

***ALWAYS KEEP YOUR WOOD COVERED YEAR ROUND.
DRY WOOD WILL PRODUCE MORE BTU OUTPUT
AND LONGER BURN TIMES.***

GENERAL INFORMATION

The central solid fuel outdoor furnace provides the most viable solution to the on going problem of homeowner utility dependence. In consideration of this fact, the Fire Chief OS2200 has been engineered to accommodate the heating requirements of the average sized home, even during winter's coldest months. It is constructed with high grade, heavy gauge steel and is continually welded to assure the utmost in structural strength. In addition, the heat exchanger is lined with firebrick to ensure many years of energy efficient service. The design of the secondary combustion chamber increases fuel efficiency by creating a "secondary burn" of smoke and wood gases before they are vented up the chimney. The cast iron door is custom fitted to provide an air tight seal, greatly extending the burn time and insuring maximum efficiency in fuel consumption. The heavy gauge cast iron grates aid in convenient ash removal and reduces maintenance; the insulated wrap around sides are designed for maximum heat transfer. For total comfort and convenience, we added a thermostatically controlled circulation blower system. This fully automatic component furnishes rapid heat disbursement to your home, minimizing recovery time. We have incorporated all of these features as standard equipment, thereby offering you the most efficient, durable and affordable appliance possible.

INCLUDED WITH YOUR OS2200 FIRE CHIEF FURNACE:

- 1 10" X 25' Insulated Flexible Heat Duct*
- 1 12" X 25' Flexible Cold Air Duct*
- 4 Clamps*
- 1 Tube Silicone*
- 1 12" Starter Collar for Cold Air Return*
- 1 Owner's Manual*

IMPORTANT FACTS ABOUT YOUR FURNACE

- **CONSULT** local building inspectors for codes concerning the installation of your furnace.
- **ALWAYS** have access to a backup generator, 2000 watt minimum.
- **USE** "Class A" Manufactured All Fuel 6" Chimney for your Fire Chief OS2200
- **NEVER** use galvanized pipe in your flue connection.
- **INSPECT** flues periodically for structural integrity.
- **CLEAN** the flue regularly to prevent creosote accumulation.
- **NEVER** use chemicals or gasoline to start or maintain your fire.
- **NEVER** burn garbage, oil, trash or gasoline in your furnace.
- **NEVER** leave the ash pan or fuel door open during operation.
- **REMOVE** ashes on a daily basis - before they reach the grates - to insure proper air flow.
- **NEVER** use wet, unseasoned wood or wood exposed to a recent rainfall - *doing so causes a rapid accumulation of hazardous creosote, a proven cause of flue fires.*
- **NEVER** burn plastics, wood products containing glue, paraffin or those treated with chemical preservatives in your Fire Chief. *The combustion of these substances may release harmful, toxic gases.*

**Always keep your wood covered year round.
Dry wood will produce more Btu output
and a longer burn time.**

INSTALLATION AND OPERATION

Before beginning your installation, consult with local authorities regarding codes governing all such installations. **DO NOT** connect your Fire Chief OS2200 Wood Furnace to any flue that services **ANY** other appliance. Your Fire Chief OS2200 must be placed outdoors on a level, non-combustible base preferably a 4' X 8' concrete pad, as close to the home as clearances to combustibles permit - do not place the furnace further than 40' from the house. The furnace must be connected to a grounded electrical circuit equipped with GFI and access to backup generator 2000 watt minimum. **Maintain the following clearances** - Sides of furnace, 12"; Rear of furnace, 12"; Front of furnace, 36"; Heat Duct, 6" for the first 16" from the rear of the furnace and 3" thereafter. Maintain the "10/2 Rule" for the chimney - the chimney cap must be 2' (two feet) higher than any part of the building within a horizontal distance of 10' (ten feet) from the chimney cap.

The Fire Chief OS2200 is an airtight outside hot air furnace with an insulated 11 cubic foot firebox that will accommodate logs to a maximum of 34" length. The 1800 cfm blower draws the cold air from the home, across the heat chamber before going through the hot air duct and returning the warmed air to your home. The blower may be operated manually or thermostatically, refer to the wiring diagram on page 11. The firebox combustion flue gases are sent back through a secondary combustion chamber producing less wasted fuel, higher efficiency and longer burn times. The smoke that remains, exits through the top of the chimney. Average burn time per load of wood, six to twelve hours depending on wood type and condition, desired temperature to maintain and amount of fuel loaded into the furnace. *Abnormally cold weather could reduce the burn time.*

The Fire Chief FCOS2200 is unlike gas or electric furnaces - a solid wood furnace can not be turned "off and on" to control the furnace temperature - once the fire is established, it has to burn, until it burns itself out. **Never leave the ash or fuel door open to attempt to regulate the fire** - this will overheat the furnace and void the warranty.

For the initial firing of your Fire Chief OS2200, connect the chimney and make electrical connections - **before adding duct work to your furnace** - build a small fire, by doing so you are giving the metals time to cure. Your new furnace will have a protective coating of oil or paint on the surface which could produce smoke or odors during the initial firing. Allow adequate ventilation during this initial break-in firing to allow any odors to escape. **DO NOT fill the firebox to full capacity during the initial firing.** After successfully completing the initial test firing, attach both the hot air duct and cold air return.

Class "A" Insulated 6" Chimney Pipe is recommended for optimum performance and must maintain a 2" clearance from combustibles. The OS2200 ships with a SuperPro2100/SuperMax™ six inch adaptor plate attached on top of the furnace for your convenience as well as brackets to attach guy wires to the four corners of the furnace to secure your chimney system. Always secure chimney with guy wires. SuperPro/SuperMax™ Chimney Pipe is readily available from your Fire Chief dealer. Using SuperPro/SuperMax™, attach the appropriate chimney pipe lengths to the adaptor, finishing with the rain cap. Your furnace requires its own chimney and can not share a flue with any other product. If using chimney pipe other than SuperPro/SuperMax™, the 6" adaptor will have to be replaced in order to fit the chimney pipe you are using.

If locating the furnace more than 10' from the home, a minimum of 6' (six feet) of chimney is required.

We recommend using insulated chimney for optimum performance, if you choose to use single wall stainless, the flue temperature will be reduced which promotes the formation of creosote, possibly creating a fire hazard. If you use single wall stainless pipe, minimum clearance is 18” from combustibles.

DO NOT use Galvanized or Black Pipe to vent your furnace it will rust out.

When installing the furnace maintain the “10/2 Rule” for the flue - the chimney cap must be 2’ (two feet) higher than any part of the building within a horizontal distance of 10’ (ten feet). Refer to Drawing:

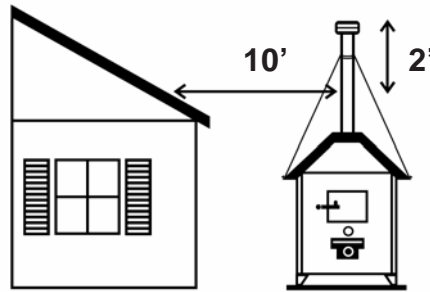

Hot Air Duct and Cold Air Return: *Included with your OS2200: 25’ of ten inch I.D. flexible insulated hot air duct and 25’ of twelve inch O.D. flexible cold air return duct. Connect with 4 clamps provided*

The factory supplied insulated flexible hot air duct on the OS2200 is ten inch (10”) - do not attempt to reduce this dimension by any means - doing so would greatly affect the performance and efficiency of the furnace. The factory supplied flexible cold air return is twelve inch (12”) and should not be reduced. The cold air return must be connected to the home in every installation - failure to do so will cause pressurization of the home and the furnace will not function. **NEVER** draw cold outside air into the blower housing - by doing so the furnace’s heat chamber temperature will not reach a level necessary to heat the house.

Duct work should be designed so the external static pressure does not exceed .02 water column inches while developing air velocities of 600 feet to 1,000 feet per minute in the main trunk duct and 400 feet to 600 feet per minute at the registers. The heat outlet area should never be less than 10” round.

The Fire Chief OS2200 MUST be installed with a cold air return system. The system must be a minimum of 12” to readily transfer the cold air back to the furnace. If desired , a cold air filter box may be constructed, minimum opening 226 square inches.

Burying Duct Work: FLEX DUCT WORK CAN NOT BE EXPOSED TO THE ELEMENTS -

The flex duct provided with the furnace must be encased in a weathertight enclosure above ground. To bury duct work below ground, use schedule 40 or 80 PVC rather than the flex provided with the furnace. Dig a trench to place both the heat duct and cold air return. The trench must be a minimum of 24” deep. To further insure efficiency, the trench may be lined with 1” (one inch) pink styrofoam sheeting insulation on the sides and bottom to prevent heat loss and moisture formation.

If you use black plastic corrugated culvert pipe underground, it should not exceed 25' and by using this type of pipe, you run the risk of reducing the furnace's efficiency and air flow. **DO NOT USE FLEX DUCT INSIDE PVC OR CULVERT PIPE.**

A basement window is an excellent location for running the hot air duct vent as well as the vent for the cold air return. The cold air flex duct is an integral part of the system and must be used when installing the furnace - failure to use the cold air return will pressurize the home causing the furnace not to work properly. It is permissible to run your electric through the cold air return duct. If a basement window is not available, you may access the home through a window or wall for both the plenum and air return.

Mobile Home:

Both the hot air duct and cold air return duct may be accessed through the floor or wall in a mobile or modular home.

**Always keep your wood covered year round.
Dry wood will produce more Btu output
and a longer burn time.**

TYPES OF INSTALLATION

Central Duct Connections: *Installation should be done by a qualified professional. Maximum run 40' - a duct run in excess of 40' will greatly restrict the air flow / heat output and is not recommended. When connecting the OS2200 to a central duct system, avoid 90 degree elbows - as with any furnace, the more turns and branches in the ducting the less air flow delivery.*

Run the 10" insulated flex hot air duct from the outside furnace through a window or wall of the house. Attach the insulated flexible hot air duct to the central duct system of the home with a 45° elbow or connecting the duct at an angle so the hot air from the OS2200 is delivered down stream. This will insure proper air flow into the duct system. Avoid delivering the hot air through the air conditioning coil as this will cause an obstruction reducing the amount of heat output. Do not reduce the size of the hot air duct. As with any furnace, the greater run, turns and branches in the ducting the less air flow and heat output delivered. Use of 90° elbows is not recommended.

The 12" cold air return duct must run to the house to prevent pressurization of the home - failure to connect the cold air return will cause the furnace not to operate. Never reduce the size of the return, doing so will restrict the hot air flow and put excess pressure on the blower motor. You may terminate the cold air return where you enter the house - this will provide adequate circulation within the home. *See diagram below.*

**Connect Hot Air at an angle,
going downstream to duct**

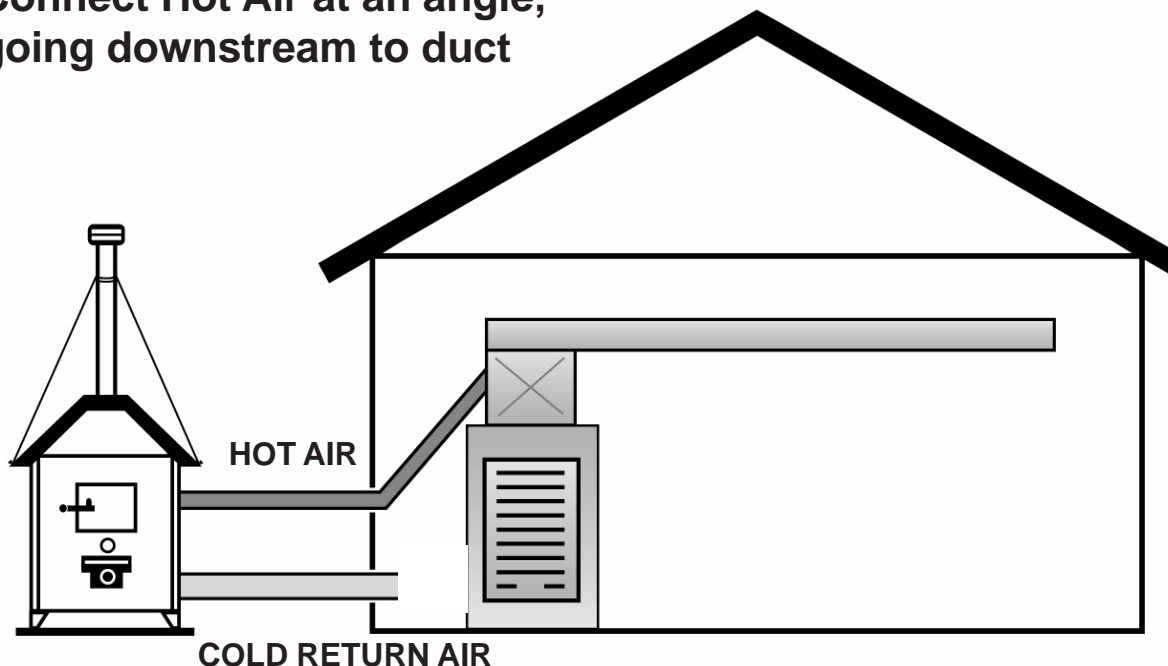

THE FLEX DUCTS MUST BE ENCLOSED AND NOT EXPOSED TO THE ELEMENTS OR OUTDOORS.

TYPES OF INSTALLATIONS, CONTINUED

Mobile Home Down Draft Furnace Connections: *Installation should be done by a qualified professional. Maximum run 40' - a duct run in excess of 40' will greatly restrict the air flow / heat output and is not recommended.*

In a mobile home, with a down-draft furnace, do not attach the hot air duct from the OS2200 to the hot air plenum doing so will cause the heat to rise through the central furnace instead of going through the duct work. Split the hot air supply of the OS2200 by using a "Y" and install one branch into each of the hot air ducts, be sure both are pointing downstream. (See diagram - maximum reduction for each "Y" duct run, 8").

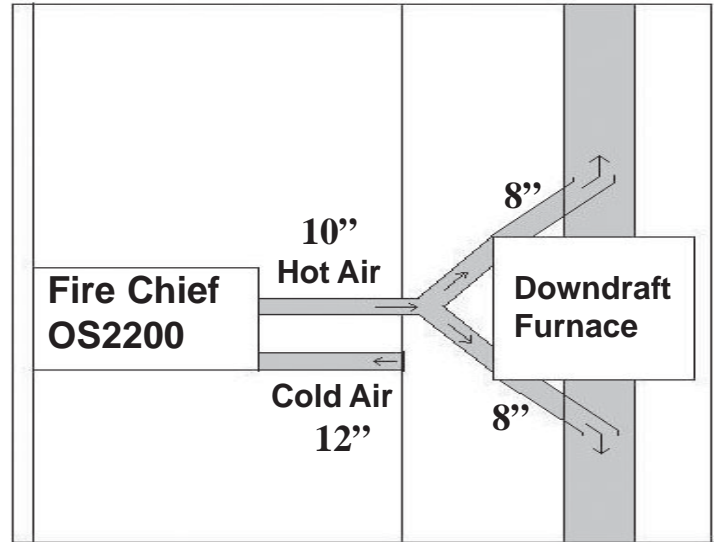

No Duct work Installation Connections: *Installation should be done by a qualified professional. Cold air return must be installed in all installations, even those without duct work.*

When there is no duct system to connect to the hot air flex duct, keep the following in mind:

1. You must separate the hot air duct from the cold air return - ideally locate each at opposite ends of the home, if you do not the air will not flow evenly throughout the home. This method will work well on homes built on concrete slabs and create a good air flow.

2. In homes with a basement, you may run the hot air duct to the basement and pull the cold air return from the main floor, this will create a perfect air flow, since hot air rises. The cold air return must be connected even if the home does not have duct work - if you do not connect the cold air return, the furnace will not be able to heat the home. See diagram below for homes with no duct work.

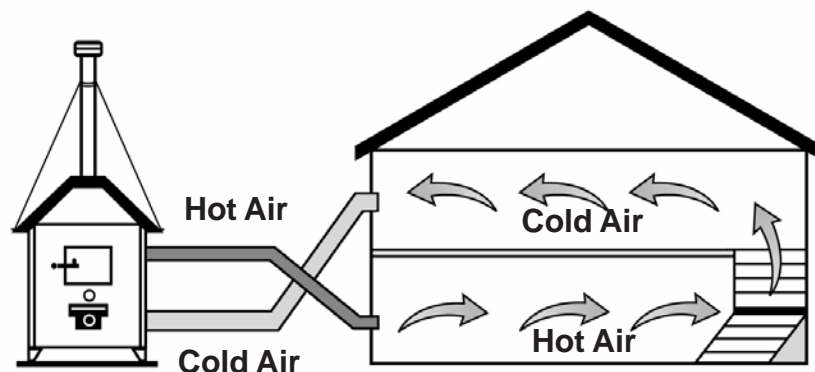

Starting your first “real fire”:

After successfully completing the initial firing: Check to be sure the spin drafts are wide open to allow oxygen into the burn chamber. Place several crumpled newspapers on the grate with some dry kindling layered on top of the papers, ignite the newspaper. When the kindling is burning, add several small pieces of wood - allow the wood to fully engage in flames. After about 10 minutes the fire should be established, allowing you to add more wood - do not overload and smother the fire - add the wood slowly so the flames have time to engulf the fresh wood. Once the fire is burning and there is a glowing ember bed, adjust the draft to achieve the desired burn pattern. Learning how to adjust the draft to achieve the desired burn for your home may take a few days. After a short time you will know which adjustment works best for your home. If you are experiencing burn times of two to four hours, you are over-firing the furnace. Over-firing by overloading/over fuelling the furnace causes the metal to super-heat and expand, then cool rapidly which causes cracking, therefore voiding the warranty. Over-firing or abuse can easily be determined upon inspection.

Caution: Never use chemicals or gasoline to start or maintain your fire. Do not burn oil, garbage, trash, plastic or any fuel other than wood in this furnace, doing so will void the warranty.

Fuel Recommendations: *MAXIMUM Log Size, 34”;* *a pair of heat resistant gloves are recommended*

We advise using only seasoned hard woods in your Fire Chief OS2200 rather than highly resinous wood such as pine. *Firewood should be cut at least one full season prior to the time of its intended use. Firewood should be stacked to provide a free flow of air between the logs, thus allowing more rapid seasoning.* If wood is to be stored outside, it should be completely covered year round to protect it from moisture and exposure to the elements.

Use extreme caution when opening the doors during operation, temperatures can exceed 300° - wait ten seconds after releasing the first latch, then proceed to the fully open position. The dual latch system has been incorporated as a safety feature - designed to eliminate the possibility of a gaseous ignition. A pair of heat resistant gloves are recommended when opening the fuel door, regulating the spin draft or removing the ash pan

Ash Removal: *A pair of heat resistant gloves are recommended*

Remove the ashes from your Fire Chief OS2200 at least once a day - or as often as necessary to ensure that the ashes do not accumulate to the height of the grates. If ash build-up occurs at grate level, it will cause premature failure of the grates, voiding the warranty on the grates. The air flow was designed to keep the grates cool in addition to providing the firebox with warmed air for better combustion. If the ash level is improperly maintained, the firebox will be starved for air, greatly reducing the efficiency and heat output of your furnace. Place hot ashes in a covered airtight metal container - place the container on a non-combustible surface. Discard the hot ashes in a safe manner.

Wood Storage:

We can not emphasize the importance of keeping your wood supply covered at all times. Wood stored/stacked, uncovered, exposed to rain and snow has a higher moisture content, causing the formation of creosote, smokes, takes longer to ignite, produces poorer fires and ends up costing more in time trying to get it up to the proper temperature. Covering the woodpile will keep it dry and offer you the hottest fires with the greatest btu output. If you store the wood near your furnace, be sure to maintain proper clearance from the furnace to prevent a fire hazard. Remember, keeping your wood dry will produce hotter fires with increased btu output.

MAINTENANCE OF THE OS2200

At the beginning and end of each heating season, take time to thoroughly check your furnace and chimney system. Make sure there are no leaks where the metal panels are joined or at the caulk lines, should you find a leak, hi-temp silicone will correct the problem. Check the doors for signs of rust, should rust develop, lightly sand or steel wool the surface and follow-up with black high temperature paint to keep the doors looking new. Check the gaskets, if they are frayed and burnt, replace the gasket. Check the firebricks for breakage or crumbling and replace as needed. Check the chimney pipe for signs of creosote formation, if you find creosote, thoroughly clean the chimney system - replacing the chimney cap securely so rain or snow does not run down the chimney into the firebox - if the cap is removed for any length of time when the furnace is not in use, cover the pipe so no moisture gets into the firebox. Check the chimney pipe for holes or loosened connections- replace and secure as necessary. Check the grates for signs of wear and replace as needed. Check the heat duct and cold air return to be sure they have not come loose or been damaged, if so tighten or replace as needed. Check the duct work for any air leaks that will affect the furnace's performance - airtight duct work increases efficiency and furnace performance while delivering higher Btus. Check guy wires to be sure they are secure and have not broken. Remove any accumulated ashes at the end of the season. By following these procedures your furnace will provide many years of trouble-free service.

ALWAYS:

- ☺ **Locate the OS2200 on a level, solid, non-combustible surface.**
- ☺ **Follow local codes concerning installation requirements.**
- ☺ **Connect power cord to a grounded 110 outlet with GFI.**
- ☺ **Connect cold air return to the house.**
- ☺ **Use Class "A" Insulated 6" SuperPro/SuperMax Chimney or equivalent.**
- ☺ **Follow guidelines within the manual regarding burn procedures.**
- ☺ **Operate furnace with fuel door and ash drawer closed.**
- ☺ **Inspect the furnace several times a year to insure furnace caulking is adequate.**
- ☺ **Inspect chimney pipe for creosote formation.**
- ☺ **Use dry, seasoned hardwood - maximum length, 34" - always keep your wood covered.**
- ☺ **Have access to a backup generator in case of power failure, minimum of 2000 watts.**
- ☺ **Use Guy Wire to secure chimney pipe**

NEVER:

- ☹ **Never allow anyone to operate the furnace who is not familiar with the unit.**
- ☹ **Operate furnace with spin draft wide open, unattended.**
- ☹ **Operate with the fuel door and ash drawer open.**
- ☹ **Use gasoline, oil or any other flammable liquid to start or maintain the fire.**
- ☹ **Operate your furnace without a backup power supply (generator).**
- ☹ **Fuel your furnace with wet unseasoned wood.**
- ☹ **Use 90° angles when running duct work.**
- ☹ **Operate the furnace without the chimney attached.**
- ☹ **Alter the furnace in any way.**
- ☹ **Burn garbage, plastic, wood containing glue/resins, paraffin or treated with chemical preservatives.**

PARTS DIAGRAM

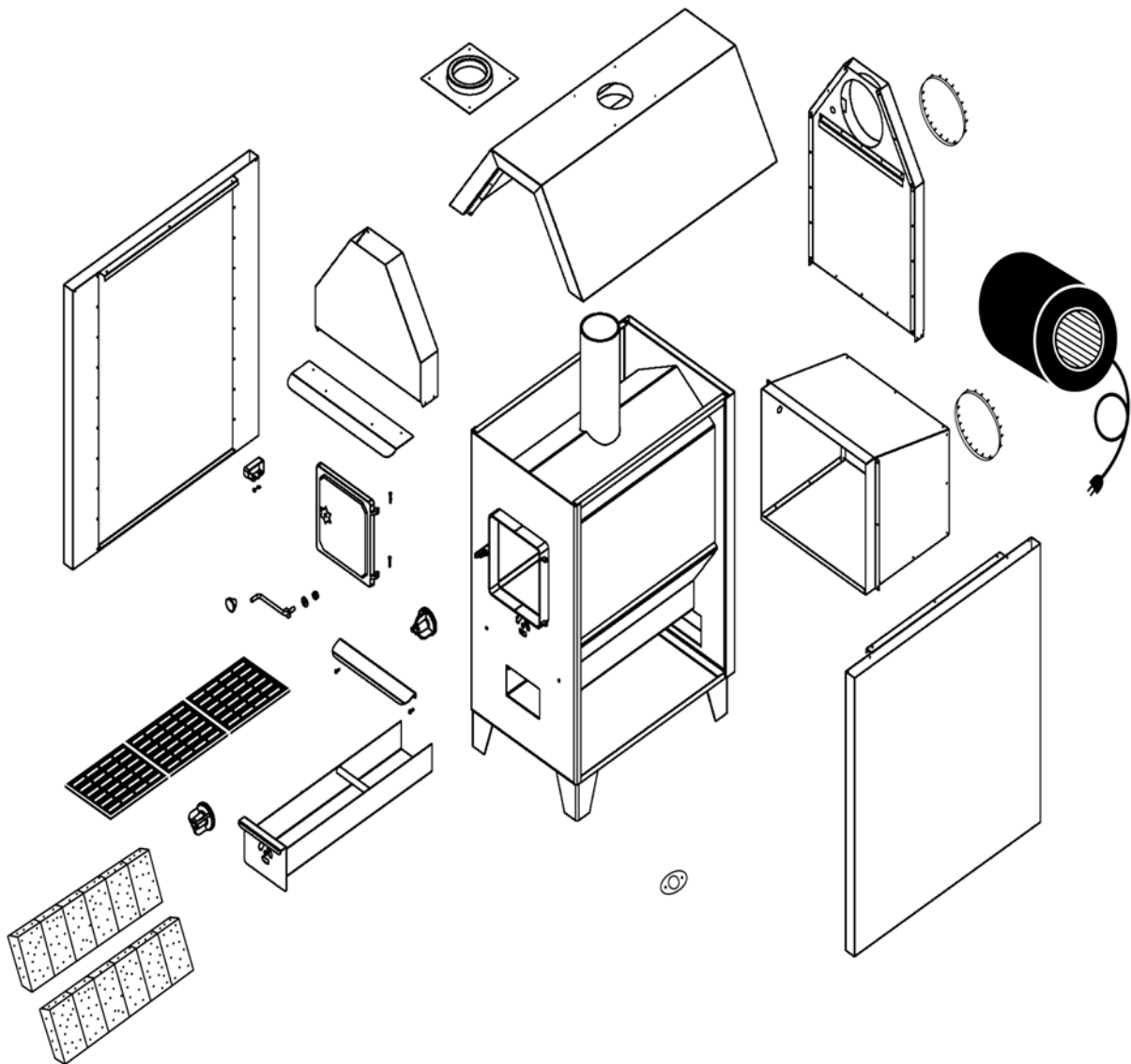

WIRING DIAGRAM

Automatic Blower Operation:
Turns "ON" at 140° and shuts
"OFF" at 130°

FAN CONTROL
SWITCH

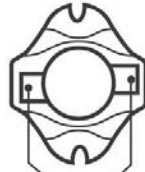

WIRE COLOR CODE

- L1 Black - Line Cord
- L2 White - Line Cord
- L3 Black - Fan Motor
- L4 White - Fan Motor
- L5 White - Fan Control Switch
- L6 White - Fan Control Switch

Manual Blower Operation:
Turning switch to "ON" will
override the thermostat and
allow you to operate the
blower manually.

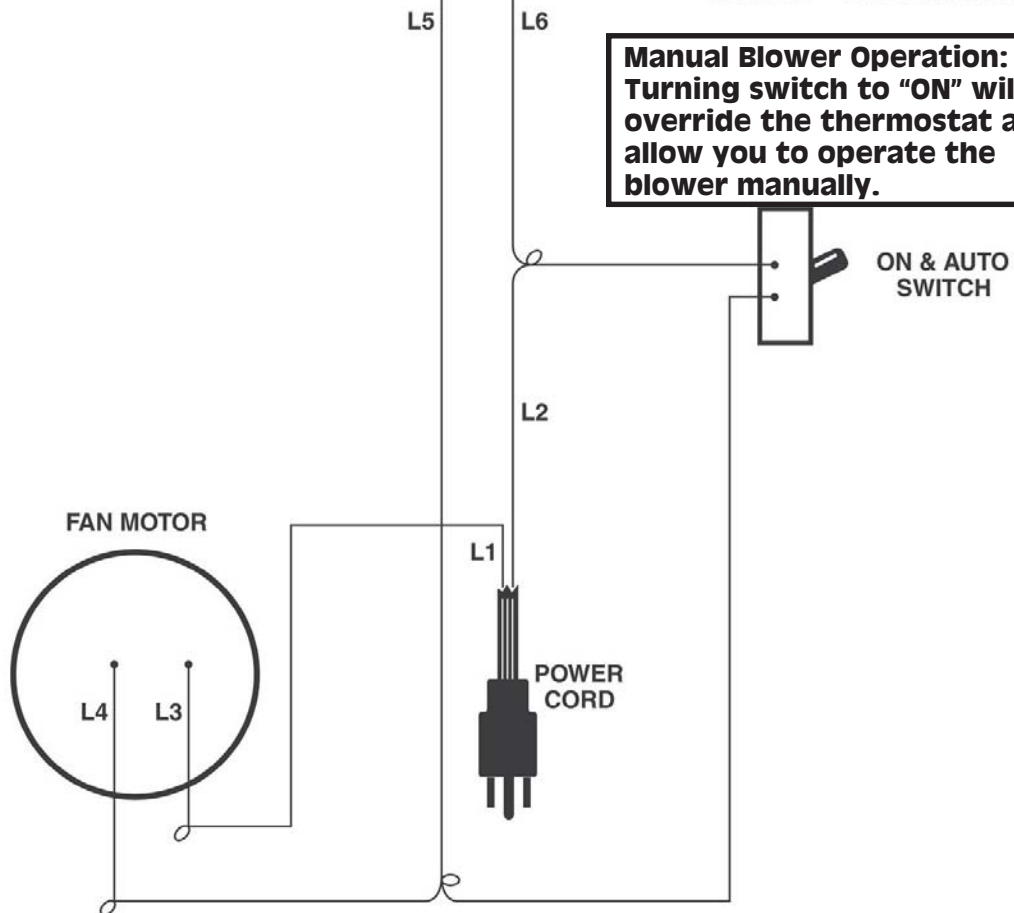

TROUBLESHOOTING

<u>PROBLEM</u>	<u>PROBABLE CAUSE</u>	<u>SUGGESTED REMEDY</u>
1. Bugs found in wood.	<ul style="list-style-type: none">• Wood has rotted or has been laying around for an extended period of time.	Inspect the wood for obvious signs of insect infestation such as burrows or holes and avoid using if possible. Do not store indoors.
2. Circulation blower will not turn on.	<ul style="list-style-type: none">• Defective fan thermodisc control.	Check by moving the switch to "ON" position, the blower should turn on. If the blower runs, replace the thermodisc.
3. Circulation blower runs continuously.	<ul style="list-style-type: none">• Switch in "ON" Position.• Defective Thermodisc• Improper wiring.	Move Switch to "AUTO" Position. Check by moving the switch to "ON" position, the blower should turn on. If the blower runs, replace the thermodisc. Review wiring diagram. If wired correctly, seek professional assistance.
4. Circulation blower vibrates during operation.	<ul style="list-style-type: none">• Screw on squirrel cage is not tight.• Balance weights on squirrel cage have become dislocated.• Defective main bearings.	Check squirrel cage alignment and position so that it does not drag on the housing during rotation; then tighten the screw sufficiently to fasten the squirrel cage securely to the shaft. You may attempt to adjust the weights yourself to obtain an acceptable balance. If you are unsuccessful, contact your supplier. Return the blower to your supplier for replacement.
5. Odor detected in home during initial firing.	<ul style="list-style-type: none">• There is an oily film that remained on the steel after the manufacturing process. Firing the unit has raised the temperature of the firebox to a level sufficient to vaporize the residue.	This odor should disappear after a few hours of usage. Refer to page 5 regarding initial firing procedure.

TROUBLESHOOTING

<u>PROBLEM</u>	<u>PROBABLE CAUSE</u>	<u>SUGGESTED REMEDY</u>
6. Smoke from the fire chamber is puffing back through spin draft knobs	<ul style="list-style-type: none"> • Chimney not high enough • Too many elbows. • Insufficient flue size. 	<p>Chimney should be a minimum of 12' from ground.</p> <p>The run should not contain more than two (2) elbows.</p> <p>Replace with a larger flue providing a minimum of fifty square inches of draft area but not more than 100 square inches of draft area. If flue is within these specifications, check the draft with a gauge. Your flue should provide a minimum of .08 water column inches.</p>
7. Down draft on chimney caused by one or more of the following	<ul style="list-style-type: none"> • Flue has a cold spot which inhibits exhaust discharge from rising properly. This symptom may occur in factory built flues because the insulation has settled or a seam has ruptured. In masonry flues, mortar loss may be causing the aspiration of cooler outside air into the stack. • There is an obstruction outside the chimney, such as a tree. • Flue is located too close to the peak of the roof or does not rise above it to provide the proper draft. • Flue is located too close to another building. • Obstruction in chimney. • Excessive ash accumulation. • Cresosote build-up. 	<p>Check entire flue for structural integrity and leakage. Correct or repair as needed.</p> <p>Remove obstruction.</p> <p>Relocate flue termination or increase height as required.</p> <p>Relocate flue termination.</p> <p>Check entire chimney system including stove pipe run. Utilize chimney cleaning device to remove any foreign matter.</p> <p>Remove if necessary.</p> <p>Clean chimney..</p>

TROUBLESHOOTING

<u>PROBLEM</u>	<u>PROBABLE CAUSE</u>	<u>SUGGESTED REMEDY</u>
8. Excessive smoke discharge from fuel door during reloading.	<ul style="list-style-type: none"> • Excessively long stove pipe run from furnace flue. • Too many elbows. • Insufficient draft. • Obstructed flue or clogged chimney cap. • Cresosote build-up. 	<p>Relocate Flue termination.</p> <p><i>SEE #6</i></p> <p><i>SEE #6</i></p> <p><i>SEE #6</i></p> <p>Clean chimney.</p>
9. Flames discharging from fuel door during reloading.	<ul style="list-style-type: none"> • Opening the door has provided additional oxygen which has ignited accumulated gases from partially spent fuel. • Insufficient natural draft or an obstruction in the flue system. • Fire chamber filled to capacity with unburned fuel. 	<p>Always open the door cautiously and allow the safety latch system to perform its designed function of containing ignite gases within the fire chamber. <i>SEE PAGE 10</i></p> <p>Open spin drafts. <i>SEE #6 AND #7</i></p> <p>Do not attempt to overload furnace.</p>
10. Excessive dirt accumulation surrounding air registers in the home.	<ul style="list-style-type: none"> • Furnace is drawing dirt and discharging through the home. 	<p>Check for leaks in return air duct system. Add filter system.</p>
11. Home does not achieve comfortable temperature.	<ul style="list-style-type: none"> • Improper connection to existing furnace. • Improperly sized ducting. • Excessive dirt accumulation in air filter. • Inadequate insulation in the home. • Spin draft not open. 	<p>Refer to information in the manual relating to the proper installation procedures or contact your local heating and cooling contractor.</p> <p>Refer to information in the manual relating to proper ducting procedures or consult your local heating and cooling contractor.</p> <p>Check and replace filter if necessary.</p> <p>Provide additional insulation.</p> <p>Open spin drafts..</p>

TROUBLESHOOTING

<u>PROBLEM</u>	<u>PROBABLE CAUSE</u>	<u>SUGGESTED REMEDY</u>
12. Rapid accumulation of creosote in furnace and flue.	<ul style="list-style-type: none">• Fueling furnace with wet or unseasoned wood. • Fueling furnace with wet or unseasoned wood. • Insufficient flue draft. • Using uninsulated stove pipe for the chimney flue. • Improper connection in stove pipe causing air leakage or structural defect in the chimney itself.	<p>Completely avoid using if at all possible. If circumstances necessitate the use of wet or unseasoned wood, fuel the furnace with smaller loads. Consequently, the fires will be hotter thereby reducing the accumulation of creosote.</p> <p>If dry, seasoned, hardwoods are not available fuel the furnace with smaller loads. Consequently, the resultant fires will be hotter, thereby retarding the accumulation of creosote.</p> <p>SEE #6</p> <p>Uninsulated pipe used as an outside flue causes rapid cooling of the stack gases, thereby causing them to condense as creosote on the inside of the flue.</p> <p>Inspect the entire flue run - from the exhaust stack of the furnace to the termination cap. Replace as necessary.</p>

CERTIFICATE OF LIMITED WARRANTY

Extent of Coverage: *This warranty covers any Fire Chief OS2200 Outdoor Furnace sold in the United States. This warranty applies only if the Fire Chief OS2200 Furnace is installed, maintained and operated safely, in accordance with the instructions in the owner's manual and local codes. This warranty applies to the original purchaser/owner of the Fire Chief OS2200 Furnace and is not transferable. Replacement or repair parts are warranted for the remaining period of the original part.*

All warranty claims must include: **date of purchase, model and serial number of furnace, proof of purchase** (*dated invoice, bill of sale, cancelled check or payment record*) and **the name and address of the dealer** from whom you purchased the furnace.

Victorian Sales warrants the *firebox* and *cast iron grates* to be free of defects in material and workmanship for *five (5) years* from date of purchase. The firebox and cast iron grates warranty will be pro-rated after *one (1) year* at a rate of 25% of the retail cost in effect per year after the first year; 50% of the retail cost the following year and so on. Intentional misuse, abuse or burn through of cast iron components is *not warranted*. **Over firing the furnace will cause the front face to crack and is not covered by warranty.** Furthermore, some aesthetic deterioration can be expected as the result of normal operation, therefore the physical appearance is not guaranteed to remain unchanged. The manufacturer warrants all electrical components *one (1) year*. Please be advised that the firebrick and door gaskets are excluded from this warranty.

In order to exercise the aforementioned warranty, a certified professional must determine the appliance/part to be defective. He or she must submit a written statement to Victorian Sales detailing his assessment of the problem. This assessment **must** be accompanied by substantiating proof of purchase (*dated invoice, bill of sale, cancelled check or payment record*), model and serial number. Victorian Sales will then authorize repair or replacement as warranted by the submitted claim. Victorian Sales will not honor expenses incurred from any action that was not expressly consented to in writing. The owner is hereby notified that he will be obligated to assume liability for removal, reinstallation, shipping and labor cost involved in servicing/repairing or replacing the part/unit. The merchandise in question must be shipped via **"PREPAID FREIGHT"** to Victorian Sales. Victorian Sales will return the repaired or replacement part to the purchaser on a **"Freight Collect"** basis.

This warranty will be rendered null and void if this part/unit exhibits symptoms of obvious over-firing, deliberate abuse or negligence, improper installation or is used for commercial purposes.

Finally, Victorian Sales will not be responsible for any claim not stated in our warranty nor does any implied warranty extend beyond the limits stated above.

If you are unable to receive satisfactory service from your local dealer, write Victorian Sales and include all pertinent information, including a daytime phone number and a detailed description of the type of problem you are having and Fire Chief Technical Service will contact you.

Mail To: Victorian Sales 1808 Larkin Williams Road Fenton, MO 63026

FOR YOUR CONVENIENCE, YOU MAY WISH TO RECORD THE FOLLOWING INFORMATION:

Fire Chief Model Number: _____

Purchase Date:

Serial Number:

Dealer where purchased:

Additional Service Information:

